

# IMV1-1/3 and IMV1-1/3NI 360° Panomorph Lenses

IMV1-1/3

IMV1-1/3NI



DC-Iris



No Iris

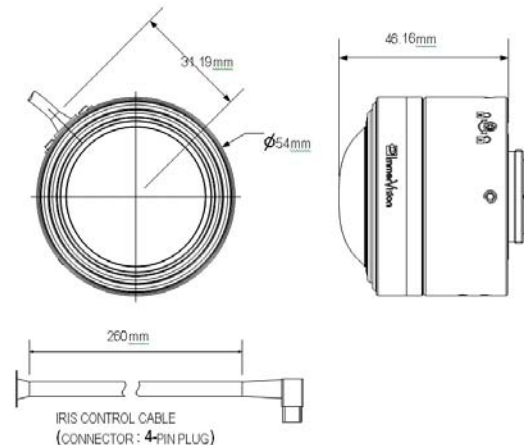

## SPECIFICATIONS

FOV	182°
Focal Length	0.9mm (short axis) 1.15mm (long axis)
Anamorphic Ratio	1.3 (4:3)
Spectral Passband	400nm to 700nm
Focal Ratio	F/1.9 (short axis) F/2.4 (long axis)
Focus	Infinity to 20mm
Focal Plane Field	3.4mm X 4.6mm (oval footprint)
MTF Performance	at 70 cycle/mm (640x480) <ul style="list-style-type: none"> <li>• On Axis &gt;60%</li> <li>• 80% diagonal &gt;50%</li> <li>• Corner &gt;35%</li> </ul>
Relative Illumination	Not less than 50% including $\cos^4$ fall off
Mount	CS (Metal Mount)
Elements	10 groups (12 elements)
Elements Material	High Quality Glass (All Elements)
Imager Size	True 1/3 inch <ul style="list-style-type: none"> <li>• Diagonal 6.00 mm</li> <li>• Width 4.80 mm</li> <li>• Height 3.60 mm</li> </ul>
Sensor Centering Adjustment	3 Axes
Iris	IMV1-1/3 Auto DC Iris IMV1-1/3NI No Iris
Weight	180 g
Operating Temperature	-20°C à +60°C

- Super wide angle of 182° x 360° that eliminates blind spots.
- Optimized design for VGA to 1.3MPx sensors, both Analog and IP cameras.
- Standard CS Metal Mount.
- Equipped with 3 Axes Sensor Centering Adjustment.
- All High Quality Glass elements.
- *ImmerVision Enables*® SDK available for DVR/NVR/VMS integration.
- Patented Panomorph Optical Technology.



PANOMORPH LENS IMAGE



## IMV1-1/3 and IMV1-1/3NI 360° Panomorph Lenses

The IMV1-1/3 is a panomorph lens dedicated to Video Surveillance Applications. This series of immersive lenses from ImmerVision have been developed using advance panomorph technology for optimal and efficient total 360° coverage.

Panomorph lenses are known to outperform older panoramic technologies such as mirror lens and fisheye lenses in regards to image quality and adaptability.

Fisheye lenses, compared to panomorph lenses, have smaller optical image sensor coverage. Furthermore fisheye lenses have a constant angular resolution rapidly decreasing the size of distant objects on the sensor (in the periphery). Like in the “ceiling mount” example below, panomorph lenses have an increased resolution on the periphery (magnification factor) increasing the size on the sensor of distant objects.

PANOMORPH VS. FISHEYE COMPARISON USING A 1.2 MEGA-PIXELS CAMERA

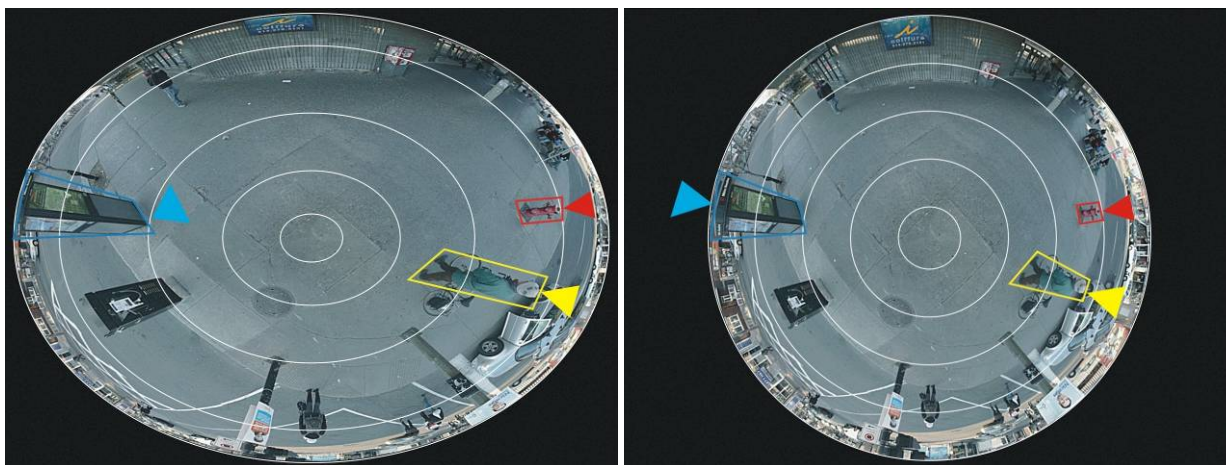

	PANOMORPH LENS	FISHEYE LENS
Blue Area	27,950 pixels (+35%)	20,696 pixels
Red Area	4,550 pixels (+119%)	2,077 pixels
Yellow Area	18,846 pixels (+101%)	9,340 pixels



IMV1-1/3 series of panomorph lenses are certified *ImmerVision Enables*<sup>®</sup>. This means that Digital Video Recorders, Network Video Recorders and Video Management Systems integrating *ImmerVision Enables* viewing functionality, offer live and playback image correction (dewarping) and digital Pan, Tilt and Zoom in a multi windows/multi operators environment.